

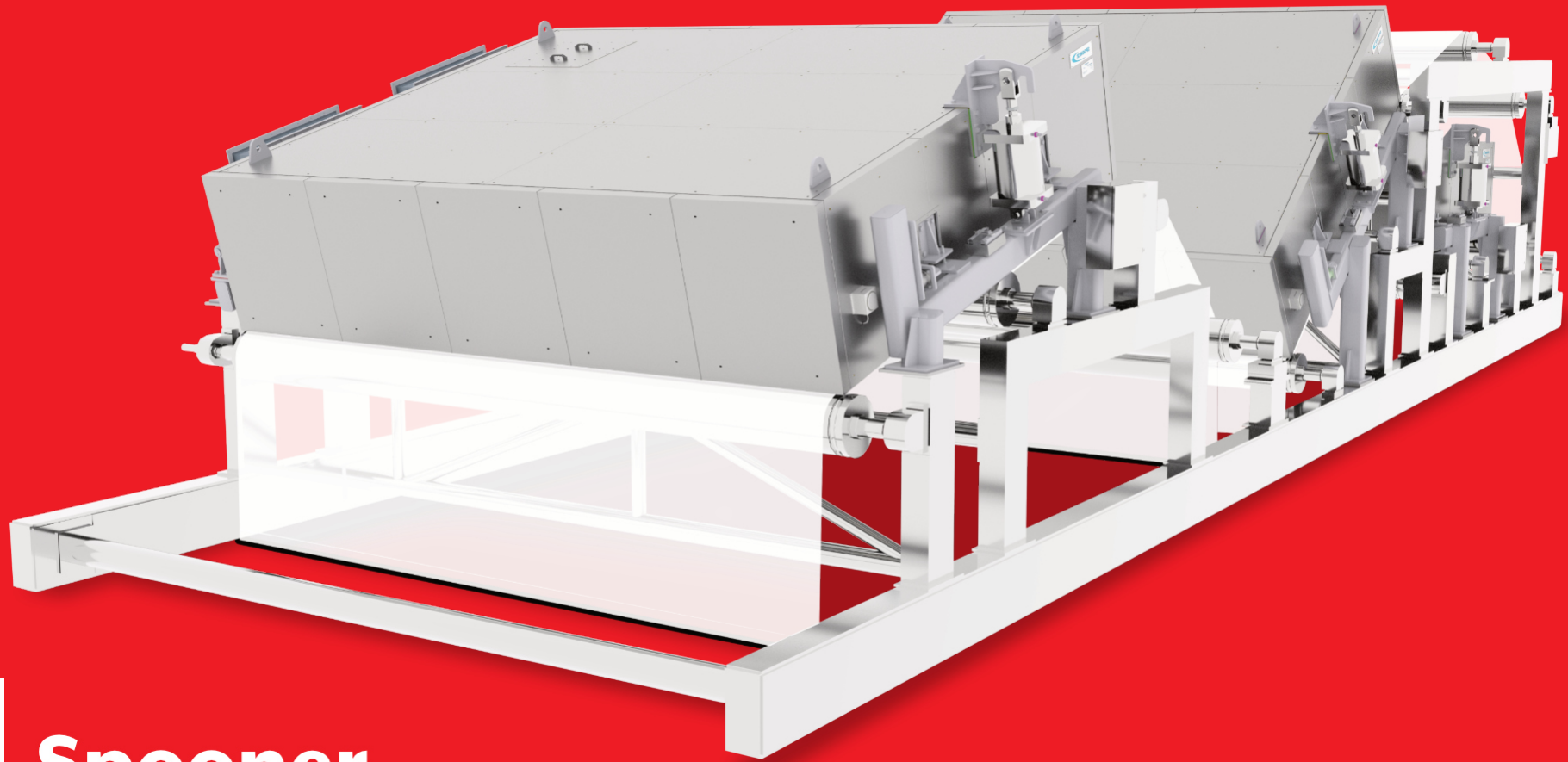

Paper Processing Specialists



Spooner Paper

Product Guide



Stable Non-Contact Handling

William Spooner revolutionised industrial processes with his forced convection technology. Since then Spooner equipment has become synonymous with high performance drying, web handling and energy efficiency across the paper processing industry.

The art of making good paper lies in the ability to fully control the process

Spooner design and manufacture all equipment to the specific requirements of the customer ensuring full control over their processes. Spooner can offer solutions for both new production machines or for re-builds of existing machines and has wide range of equipment types suitable for numerous paper and board grades.

It's what's inside that makes our equipment so effective

Spooner have been synonymous with forced air convection since the 1930s when we first applied the technology in the drying of textiles.

It was our deep understanding of airflow and thermodynamics that enabled Spooner to achieve what nobody else could at that time and led to us becoming one of the world's leading experts in the supply of industrial process equipment.

Fast forward more than 80 years and our paper division provides drying, curing, cooling and non-contact web handling solutions across a diverse range of processes in this varied sector. Customised design together with precise control of air movement and heat transfer ensures customers' process needs are consistently exceeded.

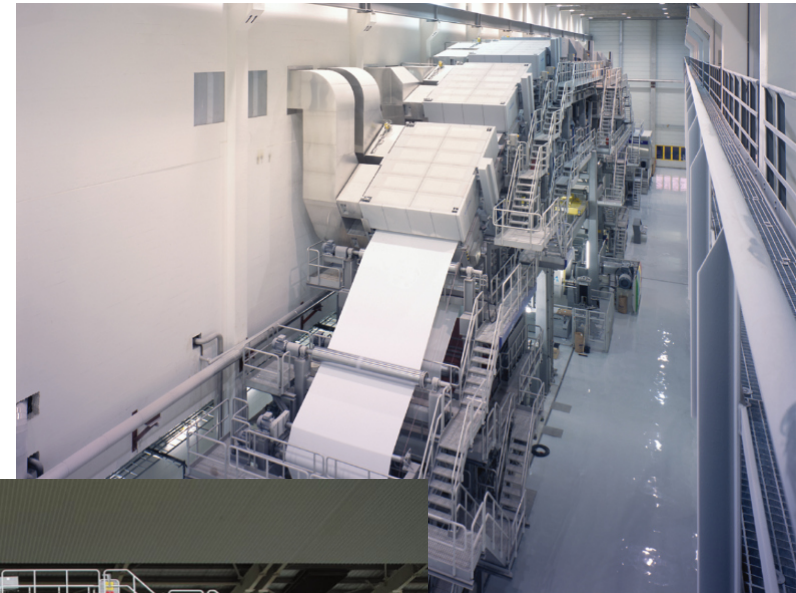

Industry Experts

Working across the different processing industries Spooner has built up lots of knowledge and experience which they bring to every project.

Its our knowledge of industry processes that help us help you

Spooner designs and manufactures for a wide range of industries including the paper, food, metals, environment and converting industry. It's this experience that provides Spooner with the expertise to design and engineer excellent dryers, ovens and coolers.

Across the paper industry, Spooner has worked with many of the biggest manufacturing companies providing tailored solutions to achieve the projects goals. Our continued research and development makes sure we continue to provide the very best solutions.

Spooner manufactures equipment for a wide range of industries



Experts in forced convection technology we engineer ovens, dryers and coolers across the process industries including paper, food, metal and converting. Our Spooner environmental division helps eliminate emissions using oxidiser technology.



Liquid and General
Packaging Board



Banknote/
Security Paper



Filter
Paper

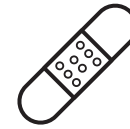

Non-woven

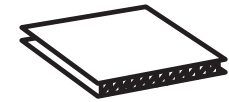

Packaging
Grades



Barriers Coated
Paper/Board



Graphical
Paper

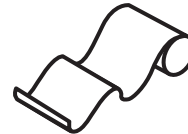

Thermally
Sensitive Paper



Speciality
Paper



Air Flotation

Excellent non-contact web handling. We understand the importance of being able to transport the web in a stable and uniform way.

Air Flotation Dryers and Ovens

Spooner's understanding and knowledge of forced convection technology is why we are regarded as market leaders in air flotation drying. Through design and development of our nozzle systems, our dryers are suitable for a wide range of substrates and processes.

Our nozzle systems offer complete non-contact operation with excellent web stability, uniform and high heat transfer. Whether lightweight paper or heavy packaging board, our dryers are designed to successfully handle any process application.

Key Features

Flotation nozzle design - Spooner has a range of nozzles providing non-contact flotation with no web vibration, flutter or wrinkles.

Dryer orientation - Spooner air flotation dryers can be orientated horizontally, vertically or on an incline without loss of performance or web handling characteristic.

Curved flotation drying - The Spooner ModuleDryer™ system provides simultaneous web turning and drying to reduce dryer footprint.

Retraction system - Various retraction options available to provide access to the web pass, including clamshell and parallel.

High performance drying - Spooner's HPC™ air flotation nozzle system delivers +30% heat transfer increase compared to conventional air flotation systems.

High aspect ratio dryers - Uniform air distribution enables very long, continuous flotation tunnels without inducing lateral web movement.

Features	Typical Specifications
Width range	+10m (no limitations)
Length range	+50m continuous tunnels available (for off machine coaters)
Heat source	Gas, steam, electric, thermal oil, recovered energy
Air temperature range	+450°C
Evaporation range (HPC™)	+200kg/m ² /hr with pre-heated web

Ease of use

Simple operation and excellent access for cleaning, threading and maintenance.

Intelligent design

Dryer is bespoke designed to individual requirements.

Superior web stability

No web flutter, vibration or contact.

Energy efficient

With efficient nozzle design, heat recovery systems, automatic exhaust control and high performance thermal insulation.

Even pressure and temperature distribution

Aiding high product quality.

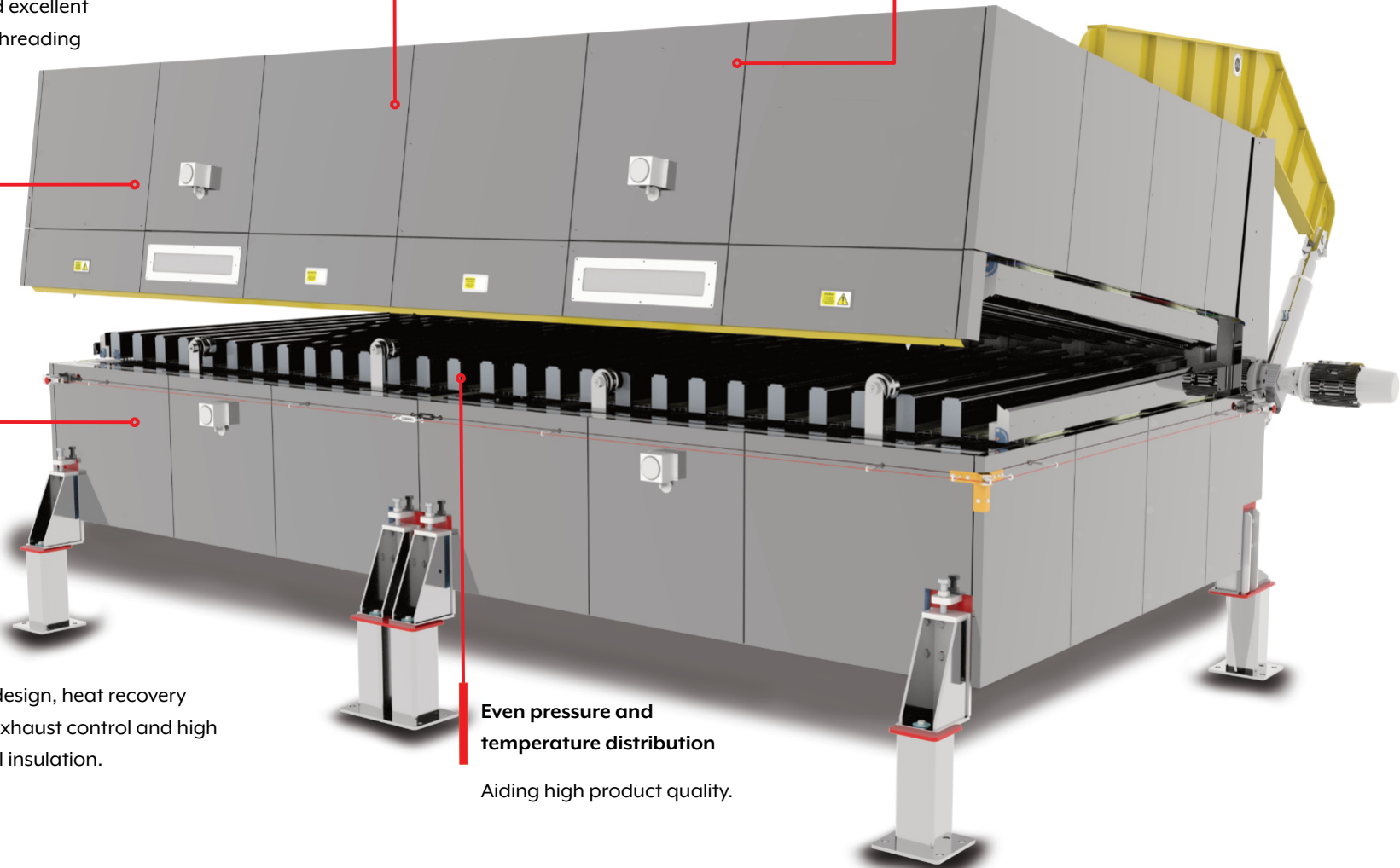



Air Impingement

High performance drying - we understand the importance of carefully managing the drying process.

Air Impingement Dryers and Ovens

It's our knowledge and understanding of heat transfer that make our impingement dryer so good. With a Spooner impingement dryer, the nozzle system is tailored to suit the application and we guarantee uniform heat transfer and control of the web.

We have been perfecting our dryer technology for over 80 years and in that time we have produced many dryers for a wide range of processes and substrates.

Key Features

Dryer orientation - Spooner impingement dryers can be orientated horizontally, vertically or on an incline without loss of performance or web handling characteristic.

Product support - Roller or conveyor depending on product.

Nozzle design - A range of nozzle designs, tailored to the process, providing effective & efficient heat transfer.

Retraction systems - Various retraction options available to provide access to the web pass, including clamshell and parallel.

Air system location - A range of built-in air system designs available as well as remote air system configuration.

Compact design - Integral fans and heaters available to reduce overall system footprint.

Features	Typical Specifications
Width range	+10m (no limitations)
Length	No limit
Heat source	Gas, steam, electric, thermal oil, recovered energy
Air temperature range	+450°C

Ease of use

Simple operation and excellent access for cleaning, threading and maintenance.

Even pressure and temperature distribution

Aiding high product quality.

Range of air flow patterns

Single and double side impingement systems available.

Energy efficient

With efficient nozzle design, heat recovery systems, automatic exhaust control and high performance thermal insulation.

Intelligent design

Dryers are designed to individual requirements.



High Performance, Quality Drying

Excellent control - we understand the importance of wrinkle-free operation.

Through AIR Dryer (TAD)

With decades of experience supplying through air dryers (TAD systems), Spooner know exactly what is required to achieve high quality products. Utilised for high porosity materials, the TAD forces heated air through the product whilst it is supported on a travelling conveyor, often achieving very high heat transfer and evaporation rates.

Spooner designs and manufactures their dryers to exact customer requirements, ensuring an optimised solution for their process requirements.

Key Features

Hybrid TAD / Impingement system - Hybrid system available that can switch between TAD and air impingement mode depending on product porosity = very wide porosity range.

Terminal end design - In-built features to prevent wrinkle formation and product disturbance entering the TAD.

Retraction system - Parallel lifting of the upper half available, providing improved access to the web pass.

Compact design - Integral fans and heaters available to reduce overall system footprint.

Deckle adjustment system - Ensures no loss of performance when running narrow product.

Air system location - A range of built-in air system designs available as well as remote air system configuration.

Features	Typical Specifications
Width	+5m
Length	No limitation
Temperature range	Up to 400°C
Dryer orientation	Horizontal or inclined

Excellent web handling

No wrinkle formation.

Ease of use

Simple operation and excellent access for cleaning, threading and maintenance.

Energy efficiency

Options of heat recovery systems to increase thermal efficiency.

High product quality

Very even pressure and temperature distribution.

High performance drying

High through air velocity and temperature capabilities.

High speed capability

Capable of high speed even at wide width.

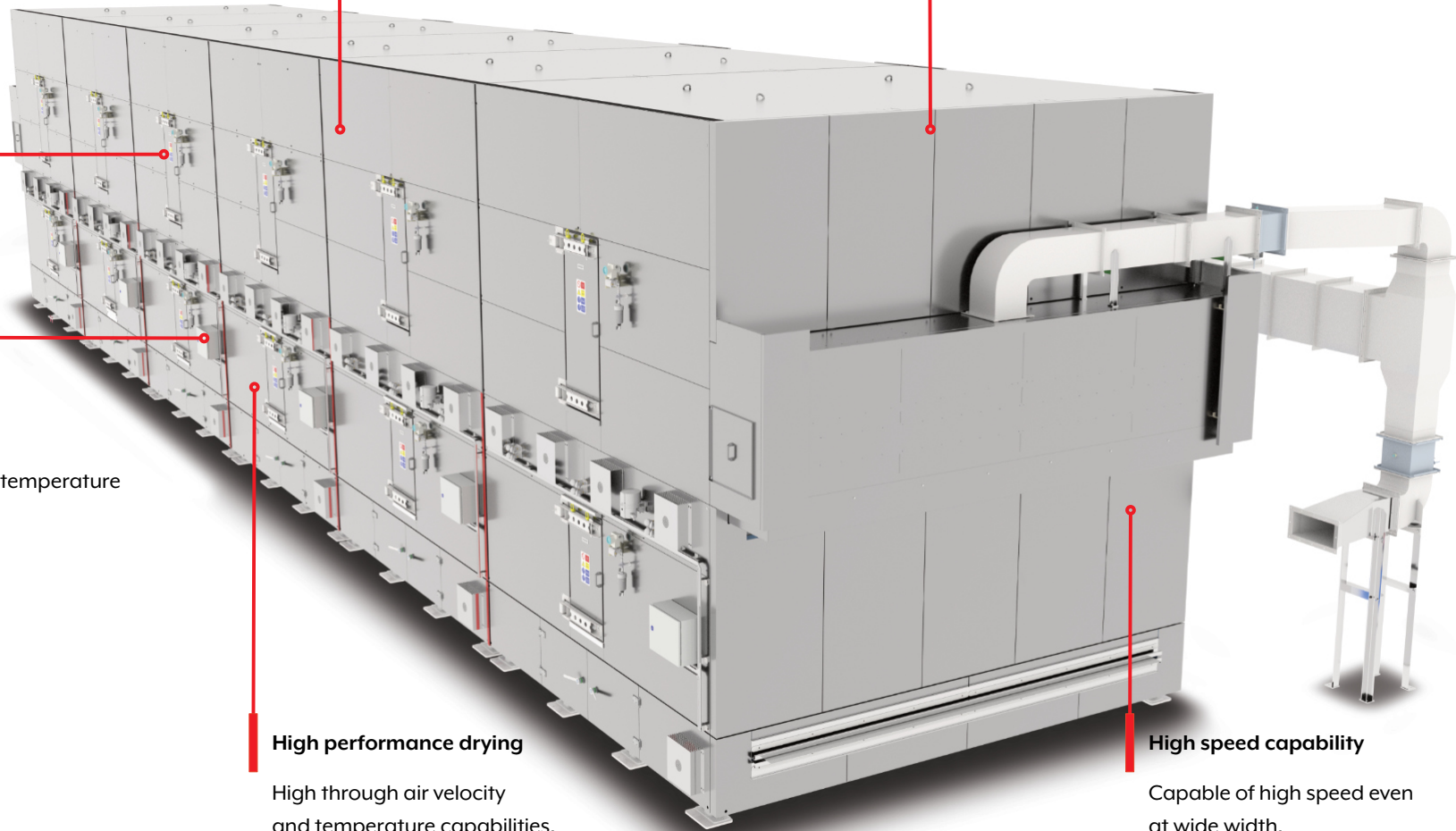



Customer Test Centre

If you're like us and have a curious nature why not come and experience our customer test centre.

Come test your products and processes

Our dedicated research and development centre gives you the opportunity to test out new coatings and materials, improve existing products or experience Spooner's capabilities. With years of web handling experience and dryer knowledge, our team can work with you to optimise your process and product quality.

Our team will work with you to explore the new possibilities.

- Develop concept ideas into new technology and test new products
- Test our technology and capabilities
- Improve current processes
- Hire for customer trials
- Toll coating/contract coating services

Our Facility

We are fully equipped to help you make your processes even better.

Our test centre offers everything needed to develop and test products.

Our facilities include:

- Reel-to-Reel high-speed coating and laminating line equipped with air flotation drying
- Hand sample pilot dryer
- Through Air (TAD) pilot dryer

Typical coating techniques:

- Direct and reverse gravure
- Offset gravure
- Chambered doctor blade
- Trailing doctor blade
- 3 roll hydrophilic (chrome roll)
- Three roll reverse
- Size press simulation

Applications

- Coating and drying pressure sensitive adhesive onto paper and films
- Coating, drying and curing paints onto aluminium foil or steel sheet
- Coating lotions onto tissue papers
- Coating and drying water-based solutions onto PET and BOPP films
- Moisturising and de-curling of papers
- Coating and drying barrier coatings onto board



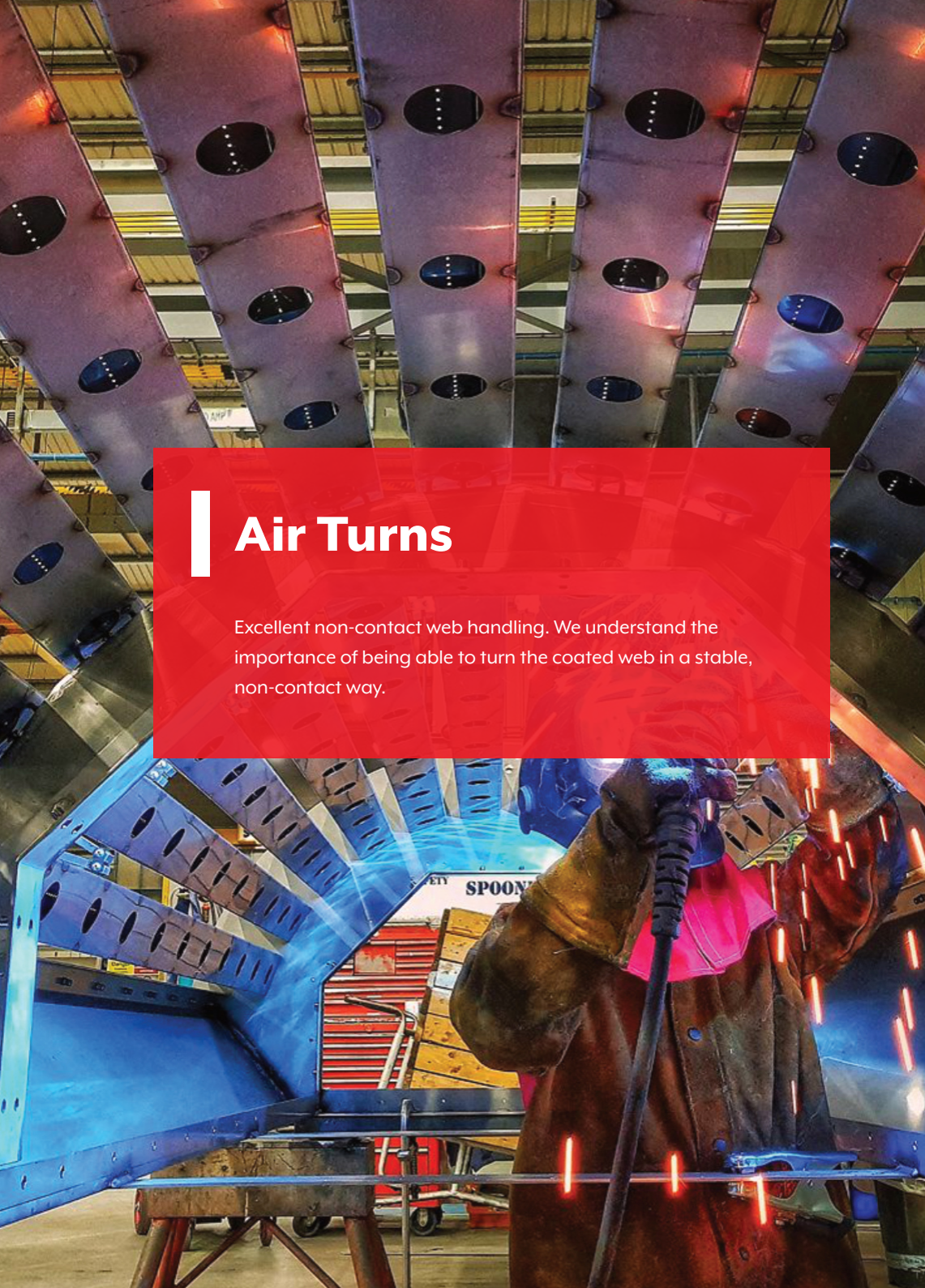

Air Turns

Excellent non-contact web handling. We understand the importance of being able to turn the coated web in a stable, non-contact way.

Air Turns

In the early 1980's, Spooner solved the problem of how to turn a coated substrate on the coated side through any given angle. The Spooner Air Turn was designed and engineered to allow easy web turning in a stable and contact free way.

A Spooner Air Turn offers stable, vibration and wrinkle free operation. Designed to individual requirements, Spooner offer a range of radii and turning angles.

Key Features:

Porous web - Specially developed Air Turn system for highly porous non-woven webs.

Heated systems - Utilising ambient or heated air.

Web types - Very lightweight papers through to heavy board can be successfully handled.

Flexible design - Wide radius, wrap angle and width range.

Automatic control system - Automatic flotation height control available - no operator intervention required. Cushion pressure signal can be used as the web tension reference.

Features	Typical Specifications
Width	+10m (no limitation)
Air Turn radius range	300 to +1000mm
Control philosophy	Auto-ride height control, auto-tension control, manual control
Web tension range	No limitation

Flexible design

With a range a radii available and no width limitation.

Superior web stability

No web vibration, flutter or wrinkles.

Easy control

Automatic control system available.

Web stabiliser

Optional web stabiliser to support the web in long unsupported draws.

Contactless operation

Achieved by creating a supporting cushion of air.

Energy efficient

Cushion conserving features minimise energy consumption.

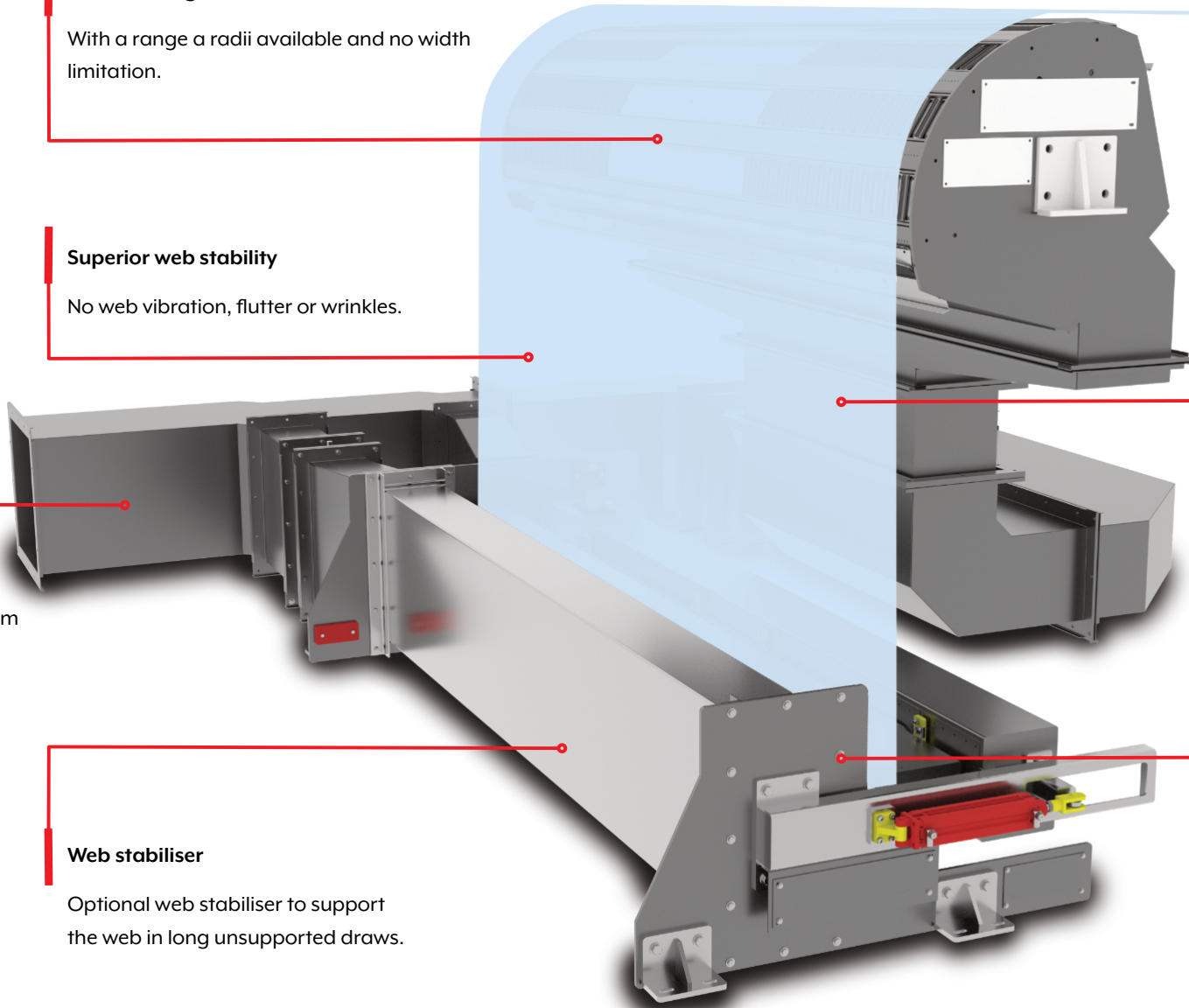



Web Cooler

High performance, non-contact cooling. We understand the importance of controlled non-contact cooling.

Web Cooler

Utilising Spooner's range of flotation and impingement nozzle designs, our web coolers deliver high performance, non-contact cooling with superior web handling. Using both ambient or chilled air to cool the web to the desired temperature.

Our coolers can also be configured to offer dual cooling and drying functions.

Key Features:

Range of nozzle design - Spooner offer both flotation and impingement nozzle systems.

No condensation - Careful design ensures condensation-free operation.

Retraction systems - Various retraction options available to provide access to the web pass, including clamshell and parallel.

Cooler orientation - Our web coolers can be oriented horizontally, vertically or on an incline without loss of performance.

Web types - Lightweight papers through to heavy board can be successfully handled using our range of air flotation and impingement nozzle designs.

Closed-loop control - Ensures consistent product temperature irrespective of ambient conditions.

Features	Typical Specifications
Width as flotation	+10m (no limitation)
Length Range	No limitations
Air Temperature Range	10 – 35°C typical
Coolant	Ambient air, mains water, glycol

Flexible design

Range of flotation and impingement designs.

Easy control

Simple operation with easy access.

Superior web stability

No web vibration, flutter or wrinkles.

Performance cooling

Utilising ambient or chilled air.

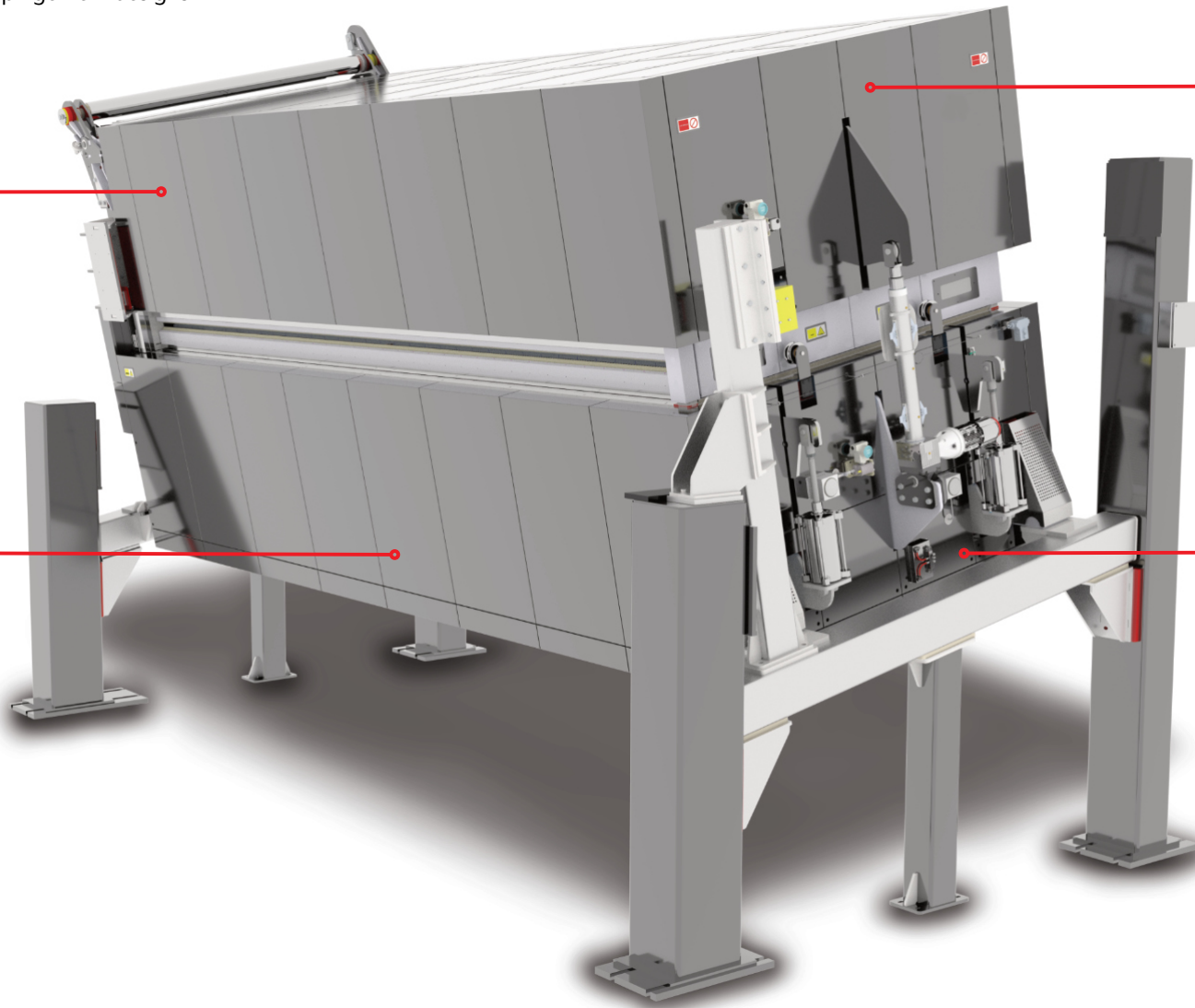



Heat Recovery Systems

Whether fitted to new or existing equipment, a Spooner heat recovery system improves your efficiency and reduces operating cost.

Huge benefits with heat recovery

Spooner design all their equipment to be as energy efficient as possible but adding a heat recovery system to your equipment can optimise your efficiency even more.

Our systems are fully automated, robust and designed for easy maintenance and cleaning.

Key features:

Easy access - System designed for easy access for cleaning and maintenance.

Robust construction - Well engineered and built to be long lasting.

Automatic control - No operator intervention required.

Bespoke design - Each system is tailor made to individual exact requirements.

Retrofits - Spooner heat recovery systems can be fitted to new or existing equipment.

Cost savings - Reduces energy consumption with good return on capital investment, often less than two years.

We provide support and maintenance for machines all over the world

You will find Spooner equipment all over the globe and with it our support and maintenance teams.

We offer end-to-end customer support from R&D and concept design, through to installation, training and maintenance.



Servicing



Refurbishments



Spares



Modifications

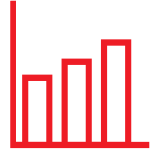

Optimisation



UK - Head Office

Spooner Industries
Moorland Engineering Works
Lower Railway Road
Ilkley

LS29 8JB
UK

Phone: +44 (0)1943 609505

Website: www.spooner-paper.com